

# WERKMASTER™

Ultra Floor Systems & Solutions

## OPERATOR'S MANUAL



The  
**EDGE**

**RASP**



**MIROIR**

**WerkMaster Grinders and Sanders Inc.**

6932 Greenwood Street, Burnaby, BC V5A 1X8

tel: 604.629.8700 | toll free: 1.866.373.WERK | fax: 604.444.4231

www.werkmaster.com | email: info@werkmaster.com

## LIABILITY LIMITATIONS

The remedies of the user set forth under provisions of warranty outlined at the end of this manual are the exclusive and total liability of WerkMaster Grinders & Sanders Inc. with the respect to their sale or the equipment and service furnished hereunder, in connection with the performance or breach thereof, or from the sale, delivery, installation, repair or technical direction covered by or furnished under the sale, whether based on contract, warranty, negligence, indemnity, strict liability, or otherwise shall not exceed the purchase price of the unit of equipment upon which such liability is based.

WerkMaster will not in any event be liable to the user, any successors in interest or any beneficiary or assignee relating to this sale for any consequential, incidental, indirect, special or punitive damages arising out of this sale or any breach thereof, or any defects on, or failure of, or malfunction of the equipment under this sale based upon loss of use, lost profits or revenue, interest, lost goodwill, work stoppage, impairment of other goods, loss by reason of shutdown or non-operation, increased expenses of operation of the equipment, cost of purchase or replacement power of claims of users or customers of the user for service interruption whether or not such loss or damage is based on contract, warranty, negligence, indemnity, strict liability, or otherwise.

WerkMaster reserves the right to modify, alter and improve any part or parts without incurring any obligation to replace any part or parts previously sold without such modified, altered or improved part or parts.

No person is authorized to give any other warranty or to assume any additional obligation on WerkMaster's behalf unless made in writing and signed by an officer of WerkMaster.

As a condition of these warranties, you are responsible for properly using, maintaining, and caring for your machine as outlined in this Owner's Manual. WerkMaster recommends that you maintain copies of all maintenance records and receipts for review by WerkMaster.

**USE ONLY GENUINE WERKMASTER PARTS AND ACCESSORIES FOR YOUR OWN SAFETY, THE SAFETY OF OTHERS AND THE LIFE OF YOUR MACHINE. THIS WARRANTY IS NOT VALID IF YOUR MACHINE HAS BEEN MODIFIED WITHOUT WERKMASTER'S AUTHORIZATION OR REPAIRED WITH UNAUTHORIZED REPLACEMENT PARTS.**

---

# CONTENTS

<b>INTRODUCTION</b> .....	<b>1</b>
<b>MACHINE DESCRIPTION</b> .....	<b>1</b>
<b>SPECIFICATIONS</b> .....	<b>3</b>
<b>SAFETY PRECAUTIONS</b> .....	<b>3</b>
Personal Protective Equipment.....	3
Physical and Mental Fitness.....	3
Safe Operating Distance.....	4
Power.....	4
Safe Operating Conditions.....	4
Modifications.....	4
<b>POWER AND CONNECTIVITY</b> .....	<b>5</b>
General Connections.....	5
Adapter Cords.....	5
Pigtails.....	5
Quick 220 Adapter.....	6
Breakout Box.....	6
Power Cord Minimum Requirements.....	6
Generator Minimum Requirements.....	6
<b>INTRODUCTION TO THE CONTROLS</b> .....	<b>7</b>
Machine Controls.....	7
VFD Controls.....	7
<b>MACHINE OPERATION</b> .....	<b>7</b>
Changing Tools.....	8
Adjusting the Dust Skirt.....	8
Adjusting the Handle.....	9
Starting the Machine.....	9
Initial Start Sequence.....	9
Adjusting the Speed.....	9
Stopping the Machine.....	9
Installing and Removing the Pad Driver.....	10
Rotation Pattern of Tooling Plates.....	10
Replacing the Shear Pins.....	10
Changing the Primary Belt.....	11
Changing the Secondary Belt.....	12
<b>VACUUM PORT</b> .....	<b>13</b>
<b>WATER FEATURE</b> .....	<b>13</b>
<b>DISASSEMBLY / ASSEMBLY INSTRUCTIONS</b> .....	<b>14</b>
<b>MAINTENANCE</b> .....	<b>15</b>
Daily.....	15
Weekly.....	15
Monthly.....	15
<b>TROUBLESHOOTING</b> .....	<b>16</b>
<b>APPENDIX – KBDA VFD troubleshooting and diagnostics</b> .....	<b>17</b>
<b>APPENDIX – LENZE VFD troubleshooting and diagnostics</b> .....	<b>18</b>
<b>EXPLODED VIEWS AND PARTS LISTS – RASP /EDGE /MIROIR</b> .....	<b>19</b>
<b>GLOSSARY</b> .....	<b>25</b>
<b>WARRANTY INFORMATION</b> .....	<b>26</b>

---

## INTRODUCTION

Congratulations on your purchase of a WerkMaster machine. WerkMaster machines allow professional surface prep, polishing, grinding, edging, buffing and restoration of virtually any surface material, including concrete, terrazzo, stone, and hardwood. This manual is provided to assist you in the operation and maintenance of your WerkMaster.

---

## MACHINE DESCRIPTION

WerkMaster machines include the SCARAB, GATOR, THE EDGE, RASP, MIROIR, COBRA, RAZOR, PYTHON, TITAN XT, and COLOSSOS XT models. To see the complete family of WerkMaster machines visit our website at [www.werkmaster.com](http://www.werkmaster.com).

**OPTIONAL:** The motor on the THE EDGE and the MIROIR can be converted to 110V 1.5HP or 220V 3HP by removing the motor assembly and replacing it with either the 110V or the 220V motor as needed. The motor assemblies can be purchased separately.

The handle of THE EDGE and the RASP can be interchanged with the water feature handle of the MIROIR (sold separately) allowing the user the versatility of wet grinding or polishing.

---

### THE EDGE



- Concrete floor edger grinder and polisher machine
- Designed to meet the needs of flooring contractors and facility services
- Excellent for concrete edging, grinding, polishing and surface prep
- Edges to within 1/8" (3 mm) of the wall
- Safely removes thinset, glues, epoxy and paint
- Levels and preps uneven floors
- Complementary to any large planetary floor machine
- Disassembles into three components for easy lifting and transport
- Lightweight and easy to maneuver
- Equipped with 6 counter rotating heads and the versatility of using our 5" (127mm) ULTRA-FLEX Plug 'N Go tooling system
- Variable frequency drive lets you run at speeds from 400 RPM to 1160 RPM
- High torque with 3:1 gear reduction
- Runs using range or dryer outlet with Breakout Box (sold separately)
- Available with either 3HP 220V or 1.5HP 110V motor
- Features dustless grinding and polishing when attached to appropriate HEPA vacuum system
- Change tooling and THE EDGE can be used to sand, screen, and edge engineered hardwood, solid hardwood, wood decks, plywood and sub-floors, and to polish terrazzo and stone

## RASP



- Professional hardwood floor sander
- Designed to meet the needs of contractors, facility services, equipment rentals and DIYers
- Use SandPaperLess Refinishing System on hardwood and engineered hardwood to safely remove aluminum oxide, wax, varnish, shellac and other floor finishes
- Use on plywood and concrete subfloors to easily removes glues, thinset, epoxy, paint, and to flatten and level uneven floors
- Refinish wood decks
- Edges to within 1/8" (3 mm) of the wall
- Disassembles into three components for easy lifting and transport
- Lightweight and easy to maneuver
- High torque with 3:1 gear reduction
- Use one machine for both field and edge
- Features dustless grinding and sanding when attached to appropriate HEPA vacuum system
- Equipped with 6 counter rotating heads and the versatility of using WerkMaster's 5" (127mm) ULTRA-FLEX Plug 'N Go tooling system, sanding discs or full plate tools
- Variable frequency drive lets you run at speeds from 400 RPM to 1160 RPM
- Runs using range or dryer outlet with Breakout Box (sold separately)
- Available with 3HP 220V
- Change tooling and the RASP can be used to grind and polish concrete, and to polish terrazzo and stone

## MIROIR



- Professional terrazzo and stone refinishing machine
- Excellent for removing sealers and contaminants, honing and polishing
- Disassembles into three components for easy lifting and transport
- Edges to within 1/8" (3 mm) of the wall
- Lightweight and easy to maneuver
- Easy to fill large mouth 4.5 gal (17 L) water tank maintains water flow
- Equipped with 6 counter rotating heads and the versatility of using our 5" (127mm) ULTRA-FLEX Plug 'N Go tooling system
- Variable frequency drive lets you run at speeds from 400 RPM to 1160 RPM
- High torque with 3:1 gear reduction
- Runs using range or dryer outlet with Breakout Box (sold separately)
- Available with either 3HP 220V or 1.5P 110V motor
- Features dustless grinding and polishing when attached to appropriate HEPA vacuum system
- Change tooling and the MIROIR can be used to sand, screen, and edge engineered hardwood, hardwood, wood decks, plywood and sub-floors, and to prep and polish concrete

## SPECIFICATIONS

MODEL	THE EDGE		RASP	MIROIR	
	230V	110V	230V	230V	110V
Dimensions: l x w in l x w cm	14.5 x 14.5 37 x 37	14.5 x 14.5 37 x 37	14.5 x 14.5 37 x 37	14.5 x 14.5 37 x 37	14.5 x 14.5 37 x 37
Disc Size: in / cm	5 / 12.7	5 / 12.7	5 / 12.7	5 / 12.7	5 / 12.7
Weight: lb / kg	206 / 93.4	206 / 93.4	206 / 93.4	212 / 96.16	212 / 96.16
Disc Speed: RPM	400-1160	400-1160	400-1160	400-1160	400-1160
Horsepower: HP	3	1.5	3	3	1.5
Phase: Ph	Single	Single	Single	Single	Single
Vacuum Req: CFM	200	200	200	200	200
Min. Generator: kW	4.5+	2.0+	4.5+	4.5+	2.0+
Frequency: Hz	50 / 60	50 / 60	50 / 60	50 / 60	50 / 60

## SAFETY PRECAUTIONS

### WARNING

**Read this manual and all the safety precautions before attempting to operate WerkMaster machines. Failure to follow the safety precautions may result in severe personal injury or death. This product is intended for commercial use.**

#### Personal Protective Equipment

- Wear eye and ear protection at all times when operating WerkMaster machines. Use only ANSI/OSHA-approved safety glasses to help prevent eye injury.
- Wear appropriate clothing and footwear when operating WerkMaster machines. Do not wear loose clothing or jewelry that may become entangled in moving parts.
- Exposure to wood dust may cause health problems. To reduce your risk, work in a well-ventilated area, use a dust control system such as an industrial-style vacuum, and wear approved personal safety equipment, such as a dust or particle respirator designed to filter out microscopic particles.
- Crystalline silica from bricks and concrete and other masonry products may cause health problems. To reduce your risk, work in a well-ventilated area, use a dust control system such as an industrial-style vacuum, and wear approved personal safety equipment, such as a dust or particle respirator designed to filter out microscopic particles.

#### Physical and Mental Fitness

- **NEVER** operate WerkMaster machines under the influence of drugs or alcohol, when taking medications that impair the senses or reactions, or when excessively tired or under stress.
- Only operate and maintain WerkMaster machines if you are trained in their use and are in good physical condition and mental health. You must be physically able to handle their bulk, weight and power.

- Safe Operating Distance**
- WerkMaster machines are to be operated by one person at a time. Maintain a safe operating distance from other personnel. Keep bystanders a safe distance away during operation by blocking off the work area in all directions with roping, safety netting, or other material. Failure to do so may result in someone being injured by flying debris or being exposed to harmful dust and noise.
  - Maintain a safe operating distance from flammable materials. Sparks from the cutting action may ignite flammable materials or vapors.

- Power**
- Unplug the WerkMaster's power cord when not in use and before servicing or changing tooling plates.
  - **DO NOT** disconnect power by pulling the cord. To disconnect power, grasp the plug, not the cord. To remove twist-lock plugs, turn counter-clockwise and pull apart, and to engage the plugs, push in and turn clockwise.
  - **DO NOT** turn on the WerkMaster while it is tilted back. Any tooling fastened to the WerkMaster may eject and become a lethal projectile.
  - While in use ground this floor-finishing machine to protect the operator from electric shock. The machine is provided with a three-conductor cord and a three-contact grounding type attachment plug to fit the proper grounding type receptacle. The green (or green and yellow) conductor in the cord is the grounding wire. **NEVER** connect this wire to other than the grounding pin of the attachment plug.

- Safe Operating Conditions**
- Be sure all safety decals on the machine can be clearly read and understood. Replace damaged or missing decals immediately.
  - Maintain WerkMaster machines in safe operating condition with all guards in place and secure, all mechanical fasteners tight, all controls in working order, and the grinder configured for the job application whether concrete, stone, terrazzo, wood or other surfaces.
  - To prevent damage to your machine or severe personal injury, avoid protruding slab inserts, nails, screws, Hilti anchors, rebar, embedded bolts or any other debris, pipe extensions, machinery bases, or any objects that transmit sudden shock to the grinding assembly.
  - Inspect the tooling carefully before installing. **DO NOT** use any tooling that exhibits signs of damage, as severe personal injury or damage to the equipment could result.
  - **NEVER** leave WerkMaster machines running unattended.
  - Risk of Explosion: Grinding/polishing concrete surfaces and sanding/finishing wood floors can result in an explosive mixture of fine dust and air. Use this machine only in a well-ventilated area free from any flame, match or combustible materials.

Dust generated from sanding wood floors can spontaneously ignite or explode. Promptly dispose of any sanding dust in a metal container clear of any combustibles. Do not dispose of in a fire.

**Modifications** **DO NOT** modify WerkMaster machines. **Modifications will void the warranty** and may result in injury to persons and damage to the machine.

# POWER AND CONNECTIVITY

WerkMaster machines are outfitted with a variable-frequency drive (VFD) that allows the desired grinding speed to be selected. Along with controlling the speed of the machine, the VFD features include the following:

- Undervoltage protection (damages most single-phase motors)
- +/- 10% voltage protection
- 60 Hz and 50 Hz capability (international)
- Wide voltage range for 230V models (200–230V)
- Soft start (smaller generator requirements)
- Monitor pad speed display



**NEVER open the VFD panel while plugged in or immediately after unplugging the power cord. Severe injury or death may result.**

**General Connections** WerkMaster machines come with a variety of different plug configurations. The following table lists the plugs that are typically used.

MODEL	THE EDGE		RASP	MIROIR	
Voltage	230V	110V	230V	230V	110V
Breaker Size	20A	15A	20A	20A	15A
Phase Configuration	Single	Single	Single	Single	Single
Cord End	3 pole 2 wire 20A Twist Lock	Straight blades	3 pole 2 wire 20A Twist Lock	3 pole 2 wire 20A Twist Lock	Straight blades

**Adapter Cords** WerkMaster machines come in a variety of voltage and phase configurations. They are typically configured to operate on 208-230V single-phase power, as well as 110V using a Quick 220 Adapter.

**Pigtails** Pigtails are plug ends with unfinished bare wire on one end for hooking in to panels. Pigtails are used when connectivity is unknown, when connecting to the power grid of an unfinished building that has no power receptacles, or when operating certain generators.



**ONLY certified electricians should make and/or install a pigtail in to a panel.**



**Quick 220 Adapter**

When using the machines in a residential environment, source power may be hard to find. Plug two 110V cords from the Quick 220 into the 110V wall outlet on two (2) separate circuits on opposite sides of the panel. Plug the WerkMaster machine into the Quick 220 adapter.



**Breakout Box**

Draws power from either a stove/range or a dryer outlet and breaks it out into 2 x 20 Amp circuits that can be used to power both a WerkMaster machine and auxiliary equipment such as a vacuum or the 110V Quad Box (sold separately).



Breakout Box



Quad Box

**Power Cord  
Minimum Requirements**

The following table lists the minimum requirements for power cords.

MODEL	THE EDGE		RASP	MIROIR	
	230V	110V	230V	230V	110V
Max. Distance	300 ft	50 ft	300 ft	300 ft	50 ft
Min. Gauge Requirement	12/3	14/3	12/3	12/3	14/3

**Generator  
Minimum Requirements**

The minimum generator requirement for the 220V model is 4.5+kW. The 110V machine requires at minimum a 2.0+kW generator.



**Exercise extreme caution at all times when working with electrical power.** WerkMaster strongly recommends that only certified electricians be permitted to work with electrical power sources within customers' facility or on their job site

---

## INTRODUCTION TO THE CONTROLS

**Machine Controls** The START button (A Fig 2) is on the handle; the SPEED control (B Fig 1) is on the VFD.

**VFD Controls** The VFD controls are locked out to avoid accidentally changing necessary parameters.

---

## MACHINE OPERATION

### WARNING

**ALWAYS** turn off and disconnect power from the machine when performing any operations to the bottom of the machine. The machine and the tooling may be hot after using.

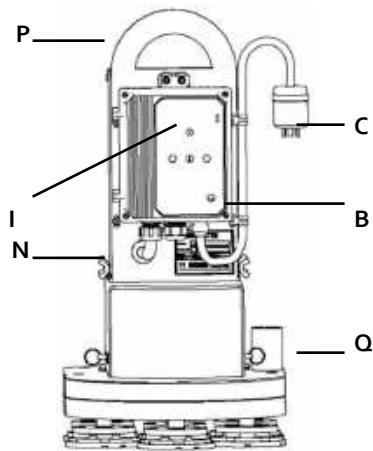

Fig. 1

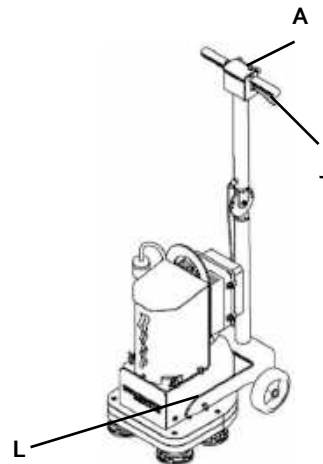

Fig. 2

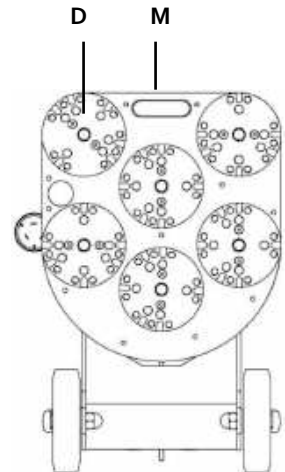

Fig. 3

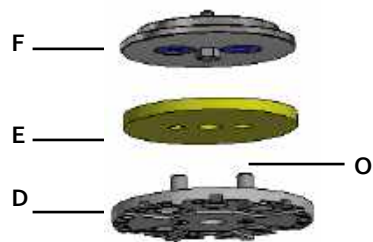

Fig. 4

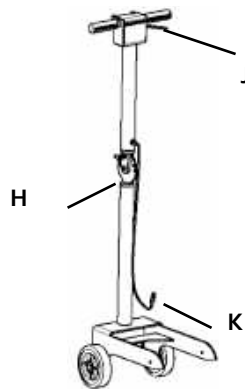

Fig. 5



Fig. 6

ILLUSTRATED MACHINE PARTS					
	Item	Fig.		Item	Fig.
A	Start Button	2	J	Activation Lever	2
B	Speed Control	1	K	Control Cable, Handle	5
C	Twist Lock Plug	1	L	Handle Arm	2
D	Plug 'N Go Plate	3	M	Handle, Base Recessed	3
E	Compression Foam	4	N	Thumbscrews	1
F	Pad Driver	4	O	Shear Pins	4
G	Dust Skirt	6	P	Handle, Motor Mounting Assembly	1
H	Pin, Adjustable Handle	5	Q	Vacuum Hose Cuff	1
I	Start Up Screen	1			

### Changing Tools To change tooling:

1. Unplug the power cord from the twist lock plug (C Fig 1).
2. Ensure the handle is in its full upright position (Fig 2). Tilt the machine back (Fig 3).
3. Choose the appropriate tooling holder attachment – magnetic Plug 'N Go plate (D Fig 4) for Metal Bond tools or Foam Hook and Loop Adapter plate for polishing resins and sandpaper.



4. Insert the two shear pins (O Fig 4) through the compression foam pad (E Fig 4) into the rubber grommets on the pad driver (F Fig 4). Attach the corresponding tooling to the plate.
5. Return the machine to the upright position (Fig 2).

### Adjusting the Dust Skirt The dust skirt (G Fig 6) serves as a seal for the bottom of the machine acting as a vacuum chamber helping the dust stay contained under the machine. If the skirt is too far from the ground, the dust containment is reduced.

To adjust the skirt:

1. Remove loop-retaining strap.
2. Pull one end of the skirt off the machine until you reach the middle of the skirt.
3. Position the skirt until it is barely touching the ground and repeat with the other end.
4. Pull the skirt snug. The two ends of the skirt should meet at the front corner but not touch. You may have a gap of up to one inch. Replace the loop-retaining strap.



## CAUTION

Avoid positioning the skirt too low as it will drag against the ground, wearing the skirt out prematurely and possibly preventing smooth machine movement.

**Adjusting the Handle** To adjust the handle, pull the pin (H Fig 5). Adjust the handle to a comfortable operating position. Release the pull pin and allow it to click into the positioning hole.

 **WARNING**

Failure to check the pull pin is fully engaged could result in damage to the machine or personal injury as the handle could release unexpectedly when the machine is being operated or tilted back.

**Initial Start Sequence** When the machine is first plugged in, a start-up screen (I Fig 1) will flash STOP.

**Starting the Machine** To start the machine, gently squeeze the activation lever (J Fig 5) and press and release the START button (A Fig 2).

 **WARNING**

**DO NOT lift the machine off the ground while starting it.** Doing so could cause the tooling to release from the machine, resulting in damage to the floor or personal injury.

**Adjusting the Speed** The speed of the machine can be adjusted when it is running or when it is stopped. To adjust the speed, rotate the speed control knob (B Fig 1) on the VFD clockwise to speed it up, or counterclockwise to slow it down. Always start the machine at the lowest speed and adjust as necessary.

Once the machine reaches the desired speed, the speed will remain constant as long as the load applied remains below 100%. If the machine is running at speed and the load begins to exceed 100%, the machine will reduce its speed as a protective measure to try and alleviate the outstanding load. The current running speed will be displayed. This happens under demanding conditions and is normal.

If the machine is not able to maintain the minimum speed for more than 30 seconds the machine will turn off. This is a normal protective measure. To prevent this from reoccurring alleviate some of the load and then resume operation.

**Stopping the Machine** Let go of the activation lever.

When the machine is unplugged, the screen will stay lit for a few seconds as the VFD drains the power from its internal capacitors. This is normal.

 **DANGER**

**NEVER open the VFD panel while plugged in or immediately after unplugging the power cord. Severe injury or death may result.**

### Installing and Removing the Pad Driver

To install and remove the pad driver (F Fig 4) on the bottom of the machine, you will need a 17 mm socket wrench, a soft face mallet, and some medium-strength threadlocker (blue Loctite 243 or equivalent).

To remove the pad driver:

1. Slip the 17 mm socket wrench over the pad driver bolt and strike the wrench with the soft face mallet in a counterclockwise direction to loosen the bolt; then remove the bolt.
2. When installing a new pad driver or re-installing an existing one, apply a generous amount of threadlocker compound to the bolt and the threaded drive shaft. Insert the bolt through the hole in the pad driver.

**NOTE:** Reapply threadlocking compound every time a pad driver is removed.

3. Line up the bolt to the threaded end of the shaft and start the first couple of threads.
4. Once the bolt is engaged, make sure that the drive shaft is properly seated within the pad driver slot before tightening the bolt all the way.



Failure to seat the pad driver could result in the pad driver slot being damaged, the threads in the shaft being stripped, the machine leaving heavy tool marks, and the tooling overheating.

### Rotation Pattern of Tooling Plates

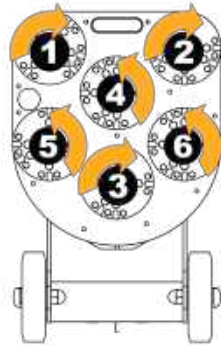

Discs 1, 2, and 3 rotate clockwise



Discs 4, 5, and 6 rotate counterclockwise

Bottom of WerkMaster with numbered tooling plates and clockwise and counterclockwise labeling.

### Replacing the Shear Pins

To replace a broken shear pin (0 Fig 4):

1. Remove the Plug 'N Go plate (D Fig 4) from the pad driver (F Fig 4). Before replacing the shear pin apply a generous amount of permanent red threadlocker (Loctite 266) on the screw and into the hole.
2. Hold the shear pin securely and firmly tighten the screw until the shear pin cannot spin. Replace the Plug 'N Go plate.

To replace a bent shear pin:

1. Remove the Plug 'N Go plate (D Fig 4). Remove the bent shear pin by hitting with a hammer. Before replacing the shear pin apply a generous amount of permanent red thread locker (Loctite 266) on the screw and into the hole; tighten.
2. Hold the shear pin securely and firmly tighten the screw until the shear pin cannot spin. Replace the Plug 'N Go plate.

**SEE:** How To Series: Replacing a Shear Pin at <http://www.werkmaster.com/replacing-a-shear-pin/>

**Changing the Primary Belt**

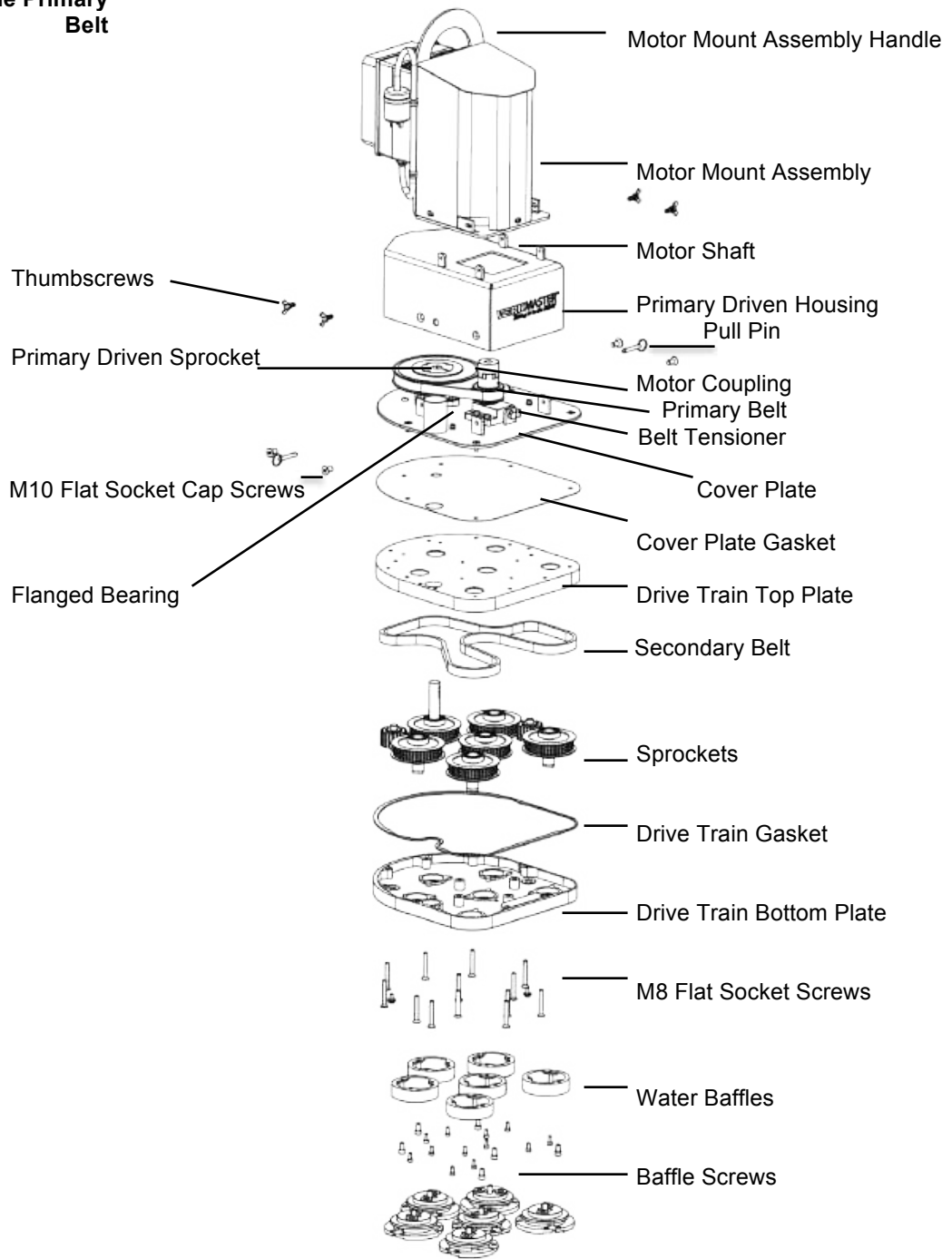

Fig. 7

To change the Primary Belt:

1. Disconnect the power and ensure the handle is in the upright position.
2. Unscrew the handle control cable (K Fig 5) from the VFD.
3. Remove the pull pins from each handle arm (L Fig 2) and roll the handle assembly away from the machine.
4. Remove the four thumbscrews (N Fig 1) from the motor mounting assembly.
5. Use the handle (P Fig 1) on the motor mounting assembly to lift the motor mounting assembly straight up until the motor shaft is completely clear of the base.
6. Remove the four M10 flat socket cap screws on the primary driven housing (Fig 7) exposing the primary belt.
7. Loosen the four M8 hex head bolts and the M10 hex head bolt on the belt tensioner (Fig 7) and slide forward to relieve tension.
8. Remove and replace the belt.
9. Tighten the M10 hex head bolt on the belt tensioner so that the belt tension is 30 in/lb then tighten the four M8 hex head bolts.
10. Replace the primary housing and then replace the four M10 flat socket cap screws on the primary housing.
11. Lower the motor mounting assembly onto the motor shaft making sure to line up the motor coupling with the drive shaft.
12. Replace the four thumbscrews in the motor mounting assembly.
13. Roll the handle assembly back into place and reconnect the handle arms by pushing the pull pins through the holes and into the base.
14. Reconnect the handle control cable in the VFD.

### Changing the Secondary Belt

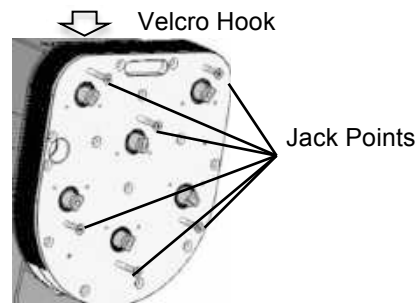

Fig. 8



Secondary Belt Path

Fig. 9

To change the secondary belt:

1. Disconnect power and ensure the handle is in the upright position (Fig 2).
2. Tilt the machine back (Fig 3).
3. Remove the Plug 'N Go plates and pad drivers (Fig 4).
4. Remove the water baffles (Fig 7).
5. Remove the thirteen M8 flat socket screws from the drive train bottom (Fig 8).
6. Insert six long M8 screws into the jack point threaded holes until snug.
7. Make a half turn of each screw clockwise until the drive train plates start to separate.
8. Carefully cut the Velcro hook with a snap-blade knife following the seam between the top and bottom plate (Fig 8).
9. Separate the drive train top plate from the drive train bottom plate exposing the sprockets and belts. Remove the jack point screws.
10. Remove the gasket.
11. Remove the broken/damaged belt.
12. Replace the belt (Fig 9).  
**NOTE:** Removing one sprocket and the shaft assembly may make the belt installation easier,

13. Replace the gasket with a new gasket.
14. Carefully line up the bottom plate with the shafts.
15. Apply Anti-Seize on the long M8 screws.
16. Thread five of the long M8 screws through the bottom plate at the four corners and one near the center.
17. Slowly and evenly make a half turn of each screw in a clockwise direction until all the shafts are lined up with the bottom plate.
18. Thread in all the remaining M8 screws and in a clockwise direction slowly clamp the drive train plates together.
19. Tighten each M8 screw to 150 in/lbs.
20. Replace the water baffles and apply blue Loctite to all water baffle fasteners.

**NOTE: DO NOT** reuse gaskets. Replace all gaskets with new ones every time the gaskets are removed or the Drive Train is opened.

---

## VACUUM PORT

### For the THE EDGE, RASP, and the MIROIR:

The vacuum recommended for all machines has a minimum CFM of 200kW.

1. **ALWAYS** run vacuum when sanding or dry grinding.
2. The vacuum port accepts a standard 2" vacuum hose cuff (Q Fig 1).
3. Always refer to vacuum manual.

**NOTE: ONLY** use a wet/dry vacuum with the MIROIR.

---

## WATER FEATURE

The MIROIR is equipped with a water feature.

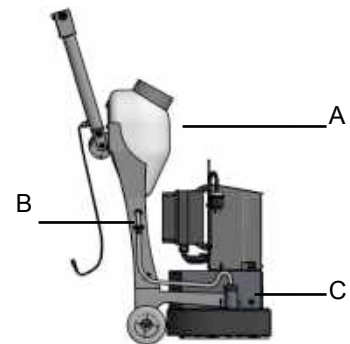

To use the water feature:

1. Ensure the flow control valve is closed (B).
2. Fill the water tank (A).
3. Insert water feature plug into the vacuum port (C).
4. Slowly open the flow control valve to the desired water flow and close as required.
5. Operate machine normally.



**DANGER**

**Use extreme caution when working with electricity and water. Severe injury or death may occur if caution is not used.**



---

## DISASSEMBLY / ASSEMBLY INSTRUCTIONS

To disassemble:

1. Disconnect power.
2. Unscrew handle control cable (K Fig 5) from VFD.
3. Remove pull pins (L Fig 2) from each handle arm and roll handle assembly away from machine).
4. Remove the four thumbscrews (N Fig 1) from the motor mounting assembly.
5. Use handle in the motor mounting assembly to lift the motor mounting assembly straight up until motor shaft is completely clear of the base.
6. Located on the bottom of the base is a recessed handle (M Fig 3) for carrying the base.



To assemble:

1. Lower the motor mounting assembly onto the motor shaft making sure to line up the motor coupling with the drive shaft.
2. Replace the four thumbscrews in the motor mounting assembly.
3. Roll the handle assembly back into place and reconnect the handle arms by pushing the pull pins through the holes and into the base.
4. Reconnect the handle control cable in the VFD.
5. Connect to power.



Motor Coupling

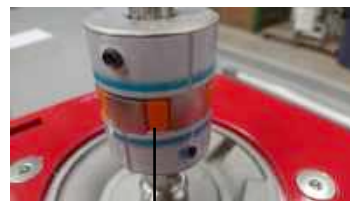

Motor Coupling Lined Up

---

## MAINTENANCE

 **WARNING**

**Disconnect power before performing any maintenance, cleaning, or repair to your machine.**

 **CAUTION**

**After wet operation, wash bottom of the machine thoroughly, failure to do so may result in damaged bearing seals.**

**Do not use any sharp object or abrasive pad to clean the bearing seals. This can compromise the bearing seals.**

- Daily**
- Wipe down the machine after every job.
  - Gently remove dirt and debris from the pad driver.
  - Check grommets and replace if necessary.
  - Vacuum, wash and thoroughly dry the underside of the machine.
  - Inspect the plug ends for signs of carbon deposits and arcing.
  - Check all fasteners and tighten if necessary.
- Weekly**
- Inspect the handle wires for damage.
  - Blow off the VFD heat sink with compressed air.
  - Using a soft scrub pad, remove any excess dirt build-up from the bottom plate and back side of the pad drivers.
  - Inspect bearings seals around shaft for any wear or damage.
  - Remove the pad drivers and inspect the threads to make sure there are no signs of cross-threading or stripping. Remove excess threadlocking compound from bolts using a wire brush or by washing the bolts in a solvent. Reapply blue threadlocking compound (Loctite 243) and reinstall pad drivers. Make sure bolts are tight.

 **CAUTION**

**After wet operation, wash bottom of the machine thoroughly, failure to do so may result in damaged shaft seals.**

**Do not use any sharp object or abrasive pad to clean the shaft seals. This can compromise the shaft seals.**

- Monthly**
- Check all strain reliefs and make sure they are tight. (Strain reliefs are the plastic nuts that secure the wires that come out of the handle and VFD.)
  - Clean and lubricate wheels.
  - Using an extremely light abrasive pad, remove any topical rust from the shafts.

## TROUBLESHOOTING

ISSUE	TEST	SOLUTIONS
Machine will not turn on.	Check all power connections. Make sure the source power meets the machine's minimum power requirements (see <i>Power Cord Minimum Requirements p. 6</i> ).	<ul style="list-style-type: none"> <li>• Plug in the machine.</li> <li>• Check to see if any breakers or fuses are tripped or blown.</li> <li>• Check to see the handle activation lever is not depressed.</li> <li>• Have a qualified electrician test the source power to see if it meets the machine's minimum power requirements.</li> <li>• Press START button while activation lever is depressed.</li> </ul>
VFD turns on but machine will not start.	Check the VFD display for error codes (see <i>Appendix p. 17</i> ).	<ul style="list-style-type: none"> <li>• If no error code is displayed, check if the control cable is plugged into the machine.</li> <li>• If the VFD error code is "low voltage" have a qualified electrician test the source power and make the necessary adjustments to the wiring to supply the machine with its required input power.</li> </ul>
Machine runs for a short time and then shuts down.	Check the circuit breaker to see if it is tripped or the fuse if it is blown.	<ul style="list-style-type: none"> <li>• Check to make sure that the power source has the appropriately sized breaker or fuse to meet the machine's minimum power requirements.</li> <li>• Make sure the generator meets the machine's minimum power requirements.</li> <li>• Have an electrician perform a voltage test while the machine is under load to see if the voltage drops below the machine's minimum power requirements.</li> </ul>
Pad drivers are not turning or only one pad driver is turning.	Disconnect the power and tilt the machine back. Spin one pad by hand.	<ul style="list-style-type: none"> <li>• If the pad turns independently, replace the secondary belt. Go to <a href="http://www.werkmaster.com/support">www.werkmaster.com/support</a>.</li> <li>• If all pad drivers turn but the motor fan does not turn, replace the primary belt. See Repair &amp; Maintenance videos at <a href="http://www.Werkmaster.com">www.Werkmaster.com</a>.</li> </ul>
Not all discs are grinding the floor.	Disconnect the power and tilt the machine back. Visually inspect each pad driver height against the adjacent pad driver.	<ul style="list-style-type: none"> <li>• Make sure all pad drivers are seated properly on the shafts.</li> <li>• Make sure grinding / polishing / sanding media is seated properly on the pad drivers.</li> <li>• Make sure grinding / polishing / sanding media is worn evenly and change out any media if uneven.</li> <li>• Make sure compression foams are positioned around the bumpers</li> </ul>
Excessive noise or vibration is felt or heard while running the machine.	Disconnect the power and tilt the machine back. Spin one pad by hand. Listen for a clicking sound or grit-like feeling.	<ul style="list-style-type: none"> <li>• Check that all tooling is in the correct pin holes on the pad drivers.</li> <li>• Replace the bearings. Contact technical support: 866-373-9375 for instructions.</li> </ul>
Tooling becomes dislodged from the machine while operating.	Disconnect the power and tilt the machine back. Remove and inspect all tooling. This includes the pins, tooling plates, and pad drivers.	<ul style="list-style-type: none"> <li>• If the pin holes are excessively damaged, replace the pad drivers.</li> <li>• If the grommets/bumpers on the pad drivers are damaged, replace the damaged parts.</li> <li>• If the pins on the diamonds or tooling plates are damaged or missing, replace the pins.</li> </ul>
The machine handle malfunctions.	Check the handle plug to see if it has come loose.	<ul style="list-style-type: none"> <li>• Secure the handle plug. If the handle controls are still malfunctioning, contact customer service for instructions.</li> </ul>
VFD makes popping noise and starts to smoke. <b>***Disconnect power immediately!***</b>	Wait for 1–2 hours, then remove the VFD cover and check electronic components for discoloration, scorching, or swelling.	<ul style="list-style-type: none"> <li>• Contact a dealer or technical support: 866.373.9375.</li> </ul>
VFD screen displays error message or unusual screen display.	Look up the message in the Appendix.	<ul style="list-style-type: none"> <li>• Contact technical support: 866.373.9375.</li> </ul>

## APPENDIX – KBDA VFD TROUBLESHOOTING AND DIAGNOSTICS

### Digital Readout Codes

The following table shows the 4-digit display readout of drive status, operating parameters, and faults.



### WARNING

**DO NOT** depend on the LEDs or the 4-Digit Display to no longer be illuminated as a guaranteed POWER OFF condition. Be sure the main power switch or circuit breaker is in the **OFF** position **BEFORE** servicing the drive.

DISPLAY	DESCRIPTION	DISPLAY	DESCRIPTION
StoP	<b>Drive Stopped</b> – Indicates that the drive is in Stop Mode. Function No. 4.03 set to “0001.”	Err2	<b>Keypad Communication Error</b> – Indicates that the keypad failed to initialize when the drive is powered up. This is an abnormal condition -
-LU-	<b>Low Voltage Trip</b> – Indicates that the AC line input voltage is below the Undervoltage Trip Point.	Err4	<b>IODA Error</b> – Indicates that the drive has lost communication with the IODA.
-OU-	<b>Overvoltage Trip</b> – Indicates that the AC line input voltage is above the Overvoltage Trip Point.	-SC-	<b>Short Circuit Fault</b> – Indicates that the drive detected a short circuit at the motor (phase- to-phase).
OL-t	<b>Overload Trip (I<sup>2</sup>t Timeout)</b> – Indicates that the motor has been overloaded for an extended period of time.	Err1	<b>Data Enter Error</b> – Indicates that the drive is in the Program Mode and a non-valid parameter change has been attempted.
CS-t	<b>Current Source Trip</b> – Indicates that the current signal output (from the IODA) has been opened.	Err3	<b>Flash Memory Error</b> – Indicates that a flash memory error on the drive has occurred. This is an abnormal condition – contact WerkMaster Technical Support at 1-604-629-8700.
-PL-	<b>AC Line Phase Loss Detection</b> – Indicates that the drive has detected a loss of one of the phases.		

## APPENDIX – LENZE VFD TROUBLESHOOTING AND DIAGNOSTICS

STATUS WARNING MESSAGES			
Status / Warning		Cause	Remedy
<b>CL</b>	Current Limit reached	Motor overload.	Press the reset button or unplug the machine for 30 seconds.
<b>Err</b>	Error	Invalid data was entered, or an invalid command was attempted.	
<b>FCL</b>	Fast Current Limit	Overload.	Verify drive/motor are proper size for application.
<b>StoP</b>	Output frequency - ) Hz (outputs U, V, W inhibited)	Stop has been commanded from the keypad, terminal strip, or network.	Apply Start command.

FAULT MESSAGES			
The messages below show how they will appear on the display when the drive trips. When looking at the Fault History (P500) the F_ will not appear in the fault message.			
	Fault	Cause	Remedy
<b>F_PF</b>	High Temperature fault	Drive is too hot inside.	<ul style="list-style-type: none"> <li>• Reduce drive load</li> <li>• Improve cooling</li> </ul>
<b>F_cft</b>	Forced Translation fault	An EPM from an old drive put in new drive causes to trip fault.	Press (M) mode button twice to reset.
<b>F_F1</b>	EPM fault	EPM missing or defective.	Power down and replace EPM.
<b>F_F2</b>	Internal faults		Contact WerkMaster technical support at 1.866.373.9375.
<b>F_FH</b>	High DC Bus Voltage fault	Mains voltage is too high.	Check mains voltage.
<b>F_LF</b>	Low DC Bus Voltage fault	Mains voltage too low.	Check mains voltage.
<b>F_nid</b>	No Motor ID fault	An attempt was made to start the drive in Vector or Enhanced VHz mode prior to performing the Motor Auto-calibration.	Contact WerkMaster technical support at 1.866.373.9375.
<b>F_OF1</b>	Output fault: Ground fault	Grounded motor phase.	Check motor/motor cable.
		Excessive capacitive charging current of the motor cable.	Use shorter motor cables with lower charging current.
<b>F_OF</b>	Output fault: Transistor fault	Output short circuit.	Check motor/motor cable.
		Severe motor overload due to <ul style="list-style-type: none"> <li>• Mechanical problem</li> <li>• Drive/motor too small for application</li> </ul>	<ul style="list-style-type: none"> <li>• Check machine/system</li> <li>• Verify drive/motor are proper size for application</li> </ul>
		Failed output transistor.	Contact WerkMaster technical support at 1.866.373.9375.
<b>F_PF</b>	Motor Overload fault	Excessive motor load for too long.	Verify drive and motor are proper size for application.
		Severe motor overload due to <ul style="list-style-type: none"> <li>• Mechanical problem</li> <li>• Drive/motor too small for application</li> </ul>	<ul style="list-style-type: none"> <li>• Check machine/system</li> <li>• Verify drive/motor are proper size for application</li> </ul>
<b>F_SF</b>	Single-Phase fault	A mains phase has been lost.	Check mains voltage.
<b>F_LF</b>	Start fault	Start command was present when power was applied.	Must wait at least two seconds after power-up to apply Start command.

**NOTE:** The drive can only be restarted if the error message has been reset.

**EXPLODED VIEWS AND PARTS LISTS – THE EDGE /RASP/MIROIR**

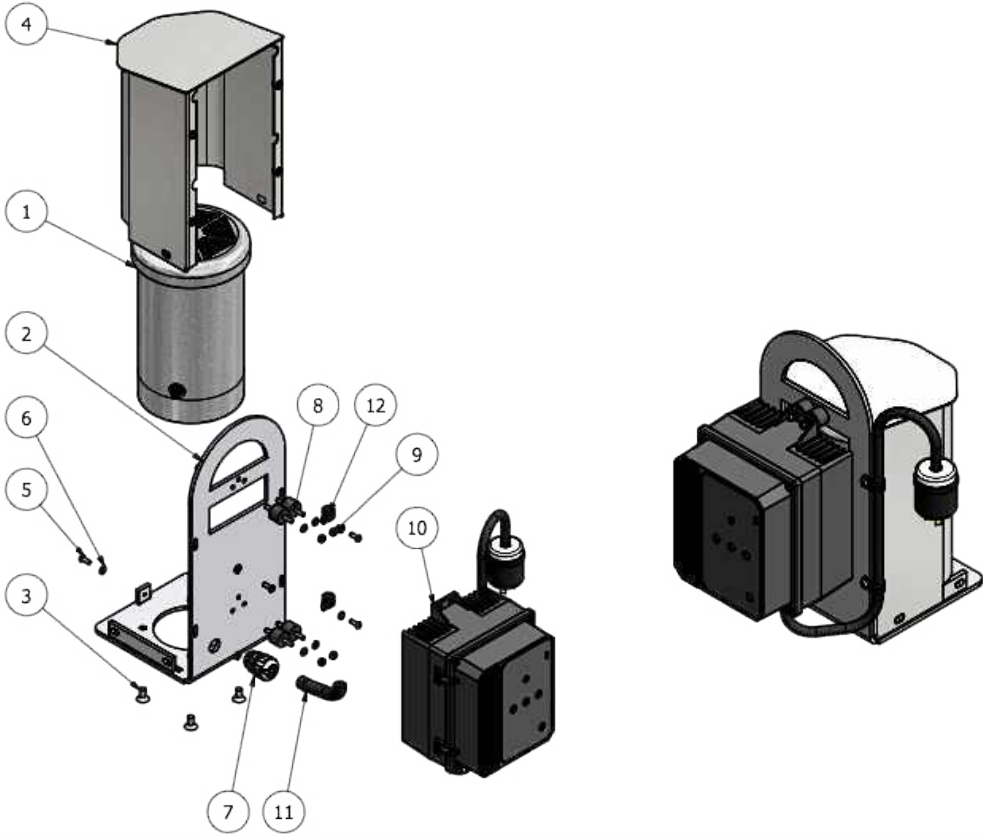

MOTOR ASSEMBLY PARTS LIST			
ITEM	QTY	PART NUMBER	DESCRIPTIOON
1	1	530-0050-00 or	Motor, 3Hp, 3Ph, 230V
	1	530-0047-00	Motor, 1.5Hp, 110V
2	1	120-0093-01	Motor Mount Assembly
3	4	590-0265-00	Fastener
4	1	120-0094-01	Motor Shroud Assembly
5	5	590-0190-00	Fastener
6	9	590-0140-00	Fastener
7	1	540-0156-00	Strain Relief
8	4	540-0375-00	Vibration Dampener
9	8	590-0133-00	Fastener
10	1	120-0101-00 or	VFD Assembly, KBDA
	1	120-0112-00	VFD Assembly, Lenze
11	1	540-0335-01	Flexible Conduit
12	2	540-0413-00	Cable Retainer

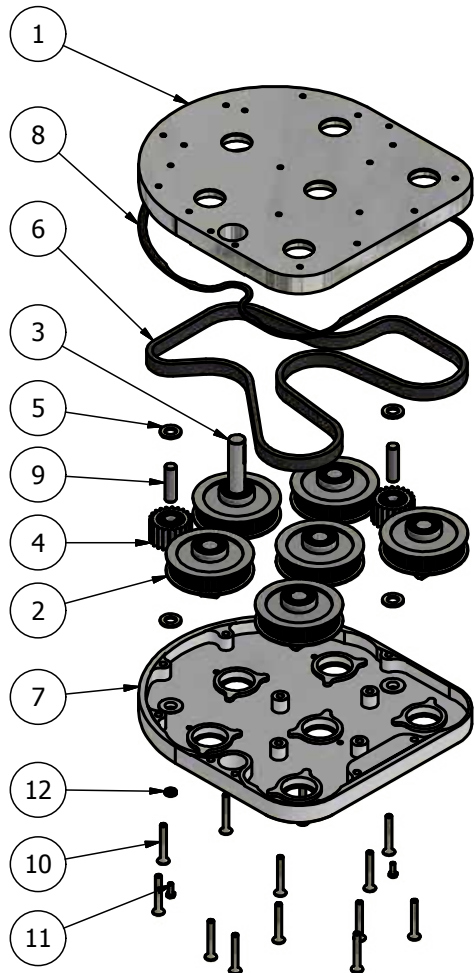

DRIVE TRAIN ASSEMBLY PARTS LIST			
ITEM	QTY	PART NUMBER	DESCRIPTION
1	1	100-1139-02	Drive Train Upper Plate
2	5	110-0177-00	Sprocket, Short Shaft Assembly
3	1	110-0182-00	Sprocket, Long Shaft Assembly
4	2	110-0092-01	Idler Assembly
5	4	590-0151-00	Flat Washer
6	1	520-0060-00	Belt
7	1	100-1138-03	Drive Train Lower Plate
8	1	580-0355-02	Drive Train Gasket
9	2	580-0357-01	Pin
10	13	590-0338-00	Fastener
11	2	590-0246-00	Fastener
12	2	590-0367-00	Washer

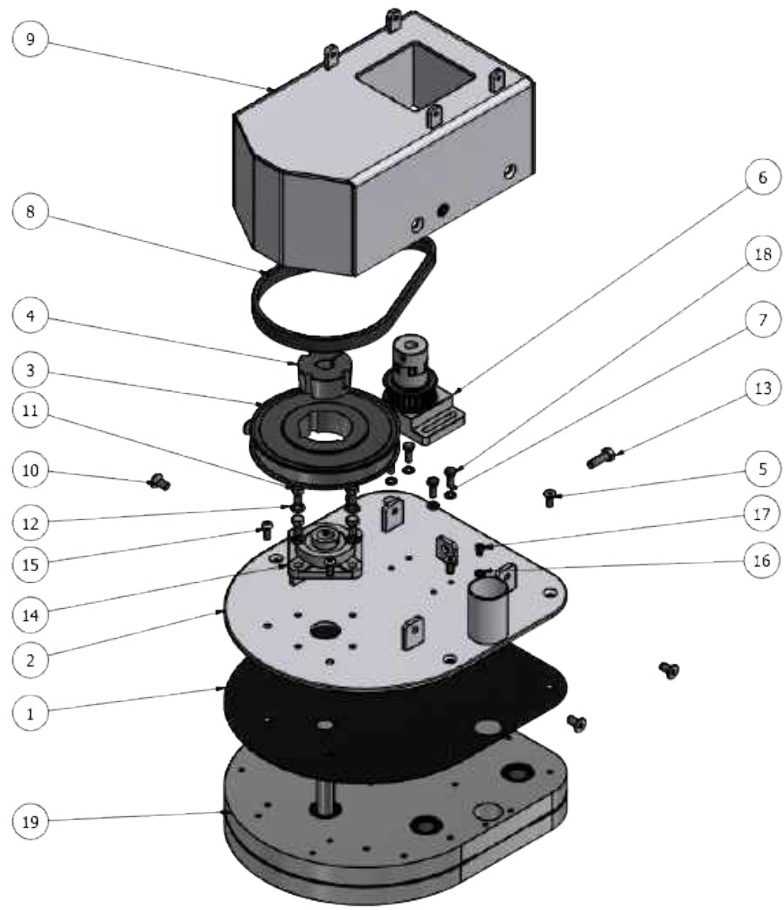

BASE ASSEMBLY PARTS LIST			
ITEM	QTY	PART NUMBER	DESCRIPTION
1	1	580-0354-01	Drive Train Cover Gasket
2	1	110-0181-01	Cover Assembly
3	1	500-0301-00	Sprocket
4	1	500-0107-00	Taper Lock Bushing
5	4	590-0193-00	Fastener
6	1	110-0208-00	Primary Drive Sprocket Assembly
7	4	590-0141-00	Fastener
8	1	520-0061-00	Belt
9	1	110-0185-01	Primary Housing Assembly
10	4	590-0329-00	Fastener
11	4	590-0124-00	Fastener
12	5	590-0142-00	Fastener
13	1	590-0126-00	Fastener
14	1	500-0306-00	Four-Bolt Flanged Pillow Block Bearing
15	2	590-0194-00	Fastener
16	4	590-0140-00	Fastener
17	2	590-0348-00	Fastener
18	4	590-0362-00	Fastener
19	1	110-0178-02	Drive Train Assembly



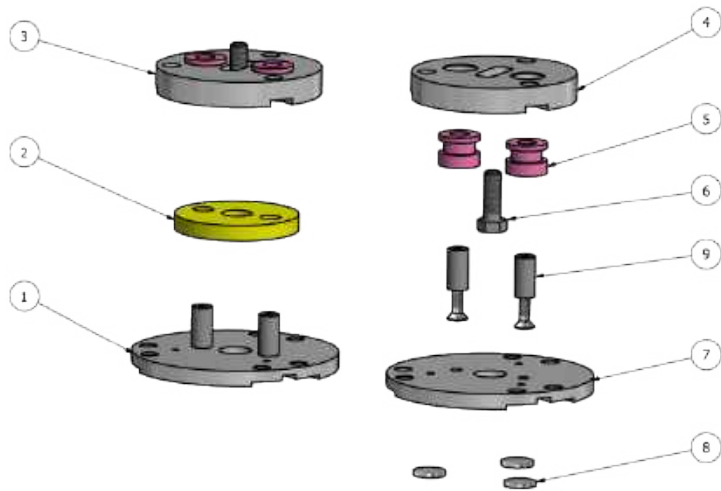

PLUG 'N GO PLATE ASSEMBLY AND PAD DRIVER ASSEMBLY			
ITEM	QTY	PART NUMBER	DESCRIPTION
1	1	008-0581-00	Plug 'N Go Plate w Recess Assembly
2	1	008-0416-00	Foam
3	1	008-0522-BK 008-0522-RD	Pad Driver Assembly EDGE/RASP Pad Driver Assembly MIRROIR
4	1	008-0523-00	Pad Driver for Water Baffle
5	2	008-0206-00	Black Grommet
6	1	590-0126-00	Fastener
7	1	008-0556-00	Plug N' Go Plate w Recess
8	6	580-0241-00	Magnet
9	2	008-0418-00	Shear Pin w Screw

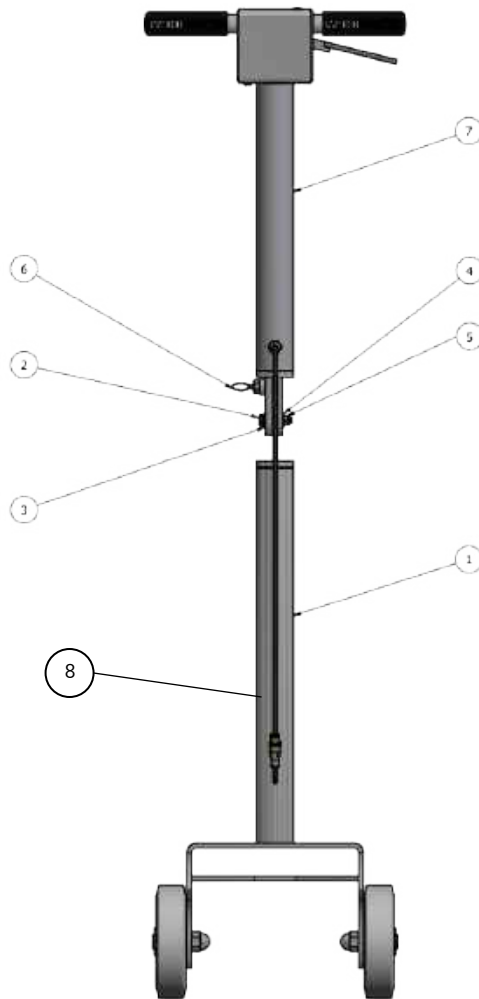

**THE EDGE / RASP HANDLE ASSEMBLY PARTS LIST**

ITEM	QTY	PART NUMBER	DESCRIPTION
1	1	130-0203-01	Complete Lower Handle Assembly
2	1	590-0300-00	Fastener
3	1	590-0149-00	Flat Washer
4	1	590-0148-00	Flat Washer
5	1	590-0196-00	Fastener
6	1	580-0362-00	Pull Pin
7	1	130-0206-01	Complete Upper Handle Assembly
8	1	540-0185-00	Four Pin Cord

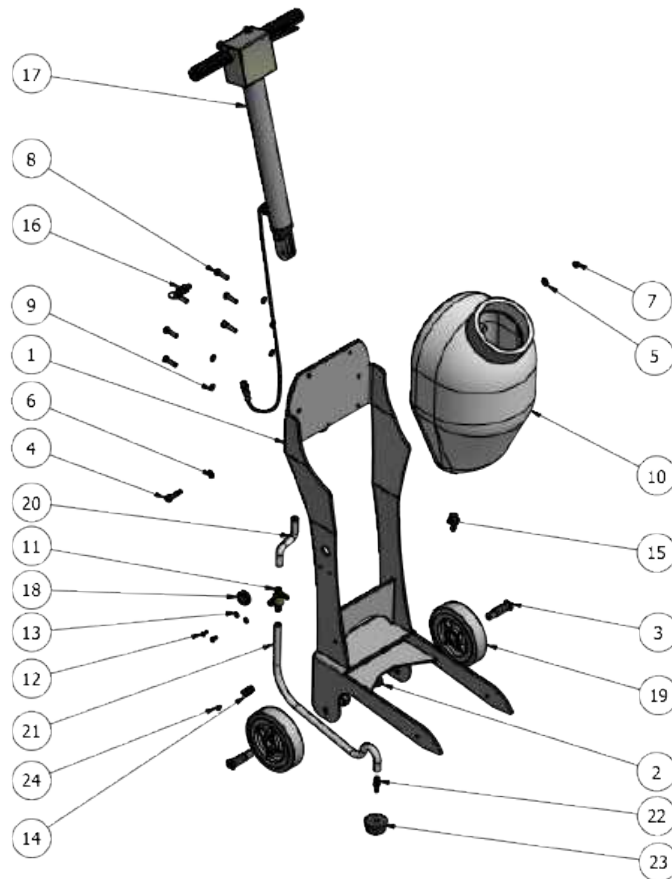

MIROIR HANDLE ASSEMBLY PARTS LIST			
ITEM	QTY	PART NUMBER	DESCRIPTION
1	1	130-0235-00	Water Feature Handle
2	2	590-0349-00	Fastener
3	2	590-0363-00	Shoulder Soc Screw
4	1	590-0300-00	Shoulder Soc Screw
5	1	590-0148-00	Fastener
6	1	590-0149-00	Fastener
7	1	590-0196-00	Fastener
8	6	590-0054-00	Fastener
9	6	590-0222-00	Lock Washer
10	1	580-0437-00	Water Tank
11	1	580-0399-00	Ball Valve
12	2	590-0114-00	Fastener
13	2	590-0140-00	Fastener
14	1	540-0413-00	Cable Retainer
15	1	580-0422-00	Hose Barb
16	1	580-0362-00	Pull Pin
17	1	130-0255-00	Complete Upper Handle Assembly
18	1	540-0426-00	Grommet
19	2	580-0091-00	Wheel
20	1	580-0439-00	Hose
21	1	580-0440-00	Hose
22	1	580-0438-00	Hose Mender
23	1	580-0236-00	Rubber Plug
24	1	590-0278-00	Fastener

---

## GLOSSARY

- Line Voltage** This is the voltage of a power source when it has no load applied to it. It can also be called “nominal voltage” as the voltage expressed is usually a guideline voltage.
- Load Voltage** This is the voltage of a power source when a load has been applied to it. As a load is applied to the power source, the resistance of the line is easier to examine. When a voltage-measuring device such as a multimeter is used during operation of the machine, you can clearly see that the voltage drops as soon as a load is applied and rises back when the load is taken off.
- Pigtail** Pigtails are plug ends with unfinished bare wire on one end used for hooking up to panels. Pigtails are used when the source power is unknown, when connecting to the power grid of an unfinished building that has no power receptacles, and when running certain generators. Many pigtails are available or can be made up by an electrician.
- RPA** Rear pivoting assembly.
- VCT** Vinyl composition tile.
- VFD** A variable-frequency drive (VFD) is a system for controlling the rotational speed of an alternating current electric motor by controlling the frequency of the electrical power supplied to the motor. A variable frequency drive is a specific type of adjustable-speed drive. Variable-frequency drives are also known as adjustable-frequency drives (AFD), variable-speed drives (VSD), AC drives, microdrives, or inverter drives. Because the voltage is varied along with frequency, these are sometimes also called variable voltage variable frequency (VVVF) drives.

---

## WARRANTY INFORMATION

WerkMaster Grinders & Sanders Inc., herein referred to as WerkMaster, warrants that each new machine, manufactured by WerkMaster to be free from defects in material and workmanship in normal use and service for a period of three years (3) from date of shipment to the original Purchaser or Distributor.

### **Terms & Conditions**

WerkMaster will, at its option, repair or replace, at the WerkMaster factory or at a point designated by WerkMaster, any part which shall appear to the satisfaction of WerkMaster inspection to have been defective in material or workmanship. WerkMaster reserves the right to modify, alter and improve any part or parts without incurring any obligation to replace any part or parts previously sold without such modified, altered or improved part or parts.

This warranty is in lieu of and excludes all other warranties, expressed, implied, statutory, or otherwise created under applicable law including, but not limited to the warranty of merchantability and the warranty of fitness for a particular purpose. In no event shall the Seller or the Manufacturer of the product be liable for special, incidental, or consequential damages, including loss of profits, whether or not caused by or resulting from the negligence of Seller and/or the Manufacturer of the product unless specifically provided herein.

In addition, this warranty shall not apply to any products or portions thereof which, at WerkMaster's discretion, have been subjected to abuse, misuse, improper installation, maintenance, or operation, electrical failure or abnormal conditions, and to products which have been tampered with, altered, modified, repaired, reworked by anyone not approved by the Seller, or used in any manner inconsistent with the provisions of the above or any instructions or specifications provided with or for the product.

Except for conditions or warranties which may not be excluded by law, the Seller makes no warranty of its own on any item warranted by WerkMaster, and makes no warranty on other items unless it delivers to the Purchaser a separate written warranty document specifically warranting the item. The Seller has no authority to make any representation or promise on behalf of WerkMaster or to modify the terms or limitations of this warranty in any way.

### **Delivery, Damages, Shortages**

Seller shall use reasonable efforts to attempt to cause the Products to be delivered as provided for in these Terms & Conditions. Delivery to the initial common carrier shall constitute the delivery to the Purchaser. Seller's responsibility, in so far as transportation risks are concerned, ceases upon the delivery of the Products in good condition to such carrier at the F.O.B. point and all the Products shall be shipped at the Purchaser's risk. Seller shall not be responsible or liable for any loss of income and/or profits, or incidental, special, consequential damages resulting from Seller's delayed performance in shipment and delivery.

### **Return of Defective Products**

Defective or failed material shall be held at the Purchaser's premises until authorization has been granted by Seller to return or dispose of Products. Products that are to be returned for final inspection must be returned Freight Prepaid in the most economical way. Credit will be issued for material found to be defective upon Seller's inspection based on prices at time of purchase.

---

## WARRANTY continued

### **FORCE MAJEURE**

Seller's obligation hereunder are subject to, and Seller shall not be held responsible for, any delay or failure to make delivery of all or any part of the Product due to labor difficulties, fires, casualties, accidents, acts of the elements, acts of God, transportation difficulties, delays by a common carrier, inability to obtain Product, materials or components or qualified labor sufficient to timely perform part of or all of the obligations contained in these terms and conditions, governmental regulations or actions, strikes, damage to or destruction in whole or part of manufacturing plant, riots, terrorist attacks or incidents, civil commotions, warlike conditions, flood, tidal waves, typhoon, hurricane, earthquake, lightning, explosion or any other causes, contingencies or circumstances within CANADA not subject to the Seller's control which prevent or hinder the manufacture or delivery of the Products or make the fulfillment of these terms and conditions impracticable. In the event of the occurrence of any of the foregoing, at the option of Seller, Seller shall be excused from the performance under these Terms and Conditions, or the performance of the Seller shall be correspondingly extended. This document sets forth the terms and conditions pursuant to which the purchaser("Purchaser") will purchase and WerkMaster ("Seller") will sell the products, accessories, attachments (collectively "the Products") ordered by the Purchaser. These terms and conditions shall govern and apply to the sale of Seller's Products to Purchaser, regardless of any terms and conditions appearing on any purchase order or other forms submitted by Purchaser to Seller, or the inconsistency of any terms therein and herein.

swm 08/2020

To get the best protection from your WerkMaster Warranty be sure to register your product(s) online at [www.werkmaster.com/warranty](http://www.werkmaster.com/warranty).

#### **WerkMaster Grinders and Sanders Inc.**

6932 Greenwood Street, Burnaby, BC V5A 1X8

tel: 604.629.8700 | toll free: 1.866.373.WERK | fax: 604.444.4231

[www.werkmaster.com](http://www.werkmaster.com) | email: [info@werkmaster.com](mailto:info@werkmaster.com)